

■ FEATURES

- Miniature size with low power consumption for rated loading to 16A.
- Surge Strength up to 10,000V.
- Operating temperature up to 105°C.
- Halogen Free series available.
- UL Class F insulation available.
- Comply with RoHS and REACH regulations.

■ SPECIFICATIONS

Contact Resistance	Max. 100mΩ at initial value. @1A,6VDC
Contact Capacity	GQ(LM1): 10Amps at 277VAC Cosφ=1 12Amps at 125VAC Cosφ=1 10Amps at 30VDC L/R=0 TV-5, 120VAC GQ(LM2F): 16Amps at 277VAC Cosφ=0.75 16Amps at 24VDC L/R=0 TV-8, 120VAC
Operate Time	10m Sec. Max.
Release Time	5m Sec. Max.
Dielectric Strength	Between coil & Contact: 4000VAC at 50/60Hz for one minute Between Contacts: 1000VAC at 50/60Hz for one minute
Insulation Resistance	100MΩ Min. at 500VDC

■ COIL SPECIFICATION AT 20°C

Coil Sensitivity	Nominal Voltage (VDC)	Nominal Current (mA)	Coil Resistance (Ω±10%)	Power Consumption (W)	Pull-In Voltage (VDC)	Drop-Out Voltage (VDC)	Max. Allowable Voltage (VDC)
GQ (LM1)	3	67	45	Abt. 0.20	80% Max.	5% Min.	110%
	5	40	125				
	6	33.3	180				
	9	22.5	400				
	12	16.7	720				
	15	13.3	1,125				
	18	11.1	1,620				
	24	8.3	2,800				
	48	4.2	11,520				

HOME APPLICATION RELAY - ETR GQ SERIES

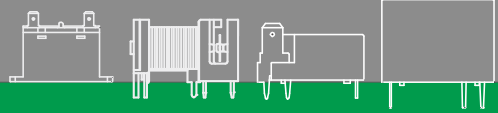

Coil Sensitivity	Nominal Voltage (VDC)	Nominal Current (mA)	Coil Resistance ($\Omega \pm 10\%$)	Power Consumption (W)	Pull-In Voltage (VDC)	Drop-Out Voltage (VDC)	Max. Allowable Voltage (VDC)
GQ (DM2F)	5	71.4	70	Abt. 0.36	80% Max.	5% Min.	110%
	6	60	100				
	9	40	225				
	12	30	400				
	15	24	625				
	18	20	900				
	24	15	1,600				
	48	7.5	6,400				
	60	6	10,000				

■ PART NUMBER SYSTEM

ETR GQ - SS - 1 12 L M 1 F Z

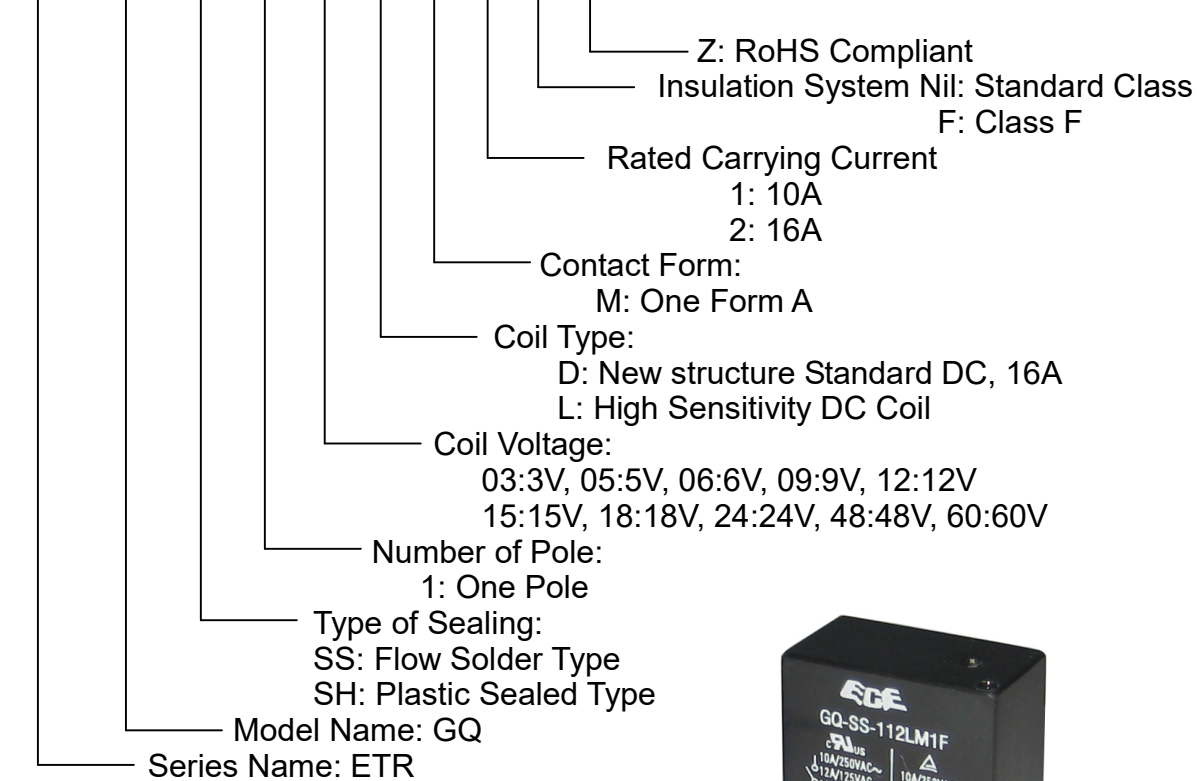

* Marking without: "ETR" & "Z".

* 16A is DM2F TYPE



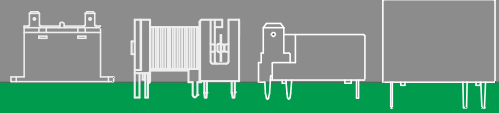

DIMENSIONS ($\leq 5\text{mm} \pm 0.2\text{mm}$, $> 5\text{mm} \pm 0.3\text{mm}$, the tolerance of PCB thru hole: $+0.1\text{mm}$)

LM1

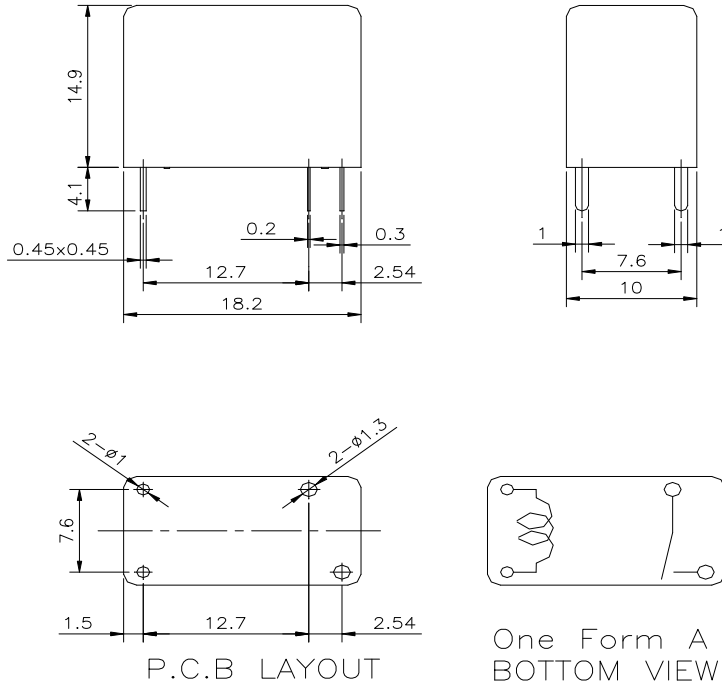

DM2F

