

5.2 x 5.2mm SMD Type

Features

1. Long life
2. Dust proof (PTA-152 & PTA-153 & PTA-154 & PTA-158)
3. Thin type
4. Reflow soldering
5. Ground terminal (PTA-154 & PTA-254)
6. Plastic stem (PTA-252 & PTA-254)
7. Metal stem (PTA-152 & PTA-154)
8. Economical type (PTA-252 & PTA-254)

Applications

Note book, Digital camera, MP3, PDA, DVD, Digital audio

Specifications

1. Rating: DC12V, 50mA Max.
2. Contact resistance: 100mΩ Max.
3. Travel: 0.25mm ± 0.1

Part numbering system

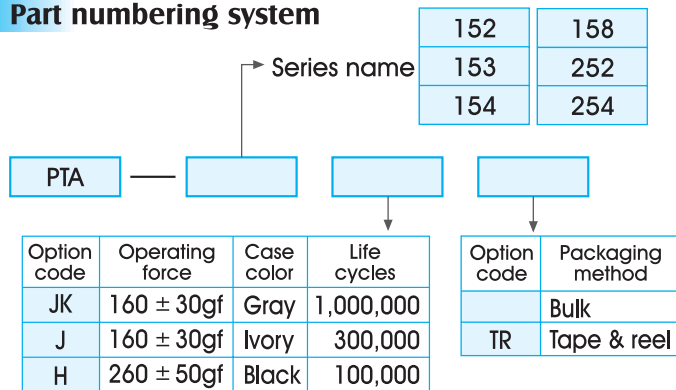

Packaging unit

1. Bulk: 1,000pcs / bag
2. Reel:
 - PTA-152, PTA-153, PTA-252: 3,000pcs/ reel
 - PTA-154, PTA-158, PTA-254: 3,500pcs/ reel

Dimensions (unit:mm)

PTA-152

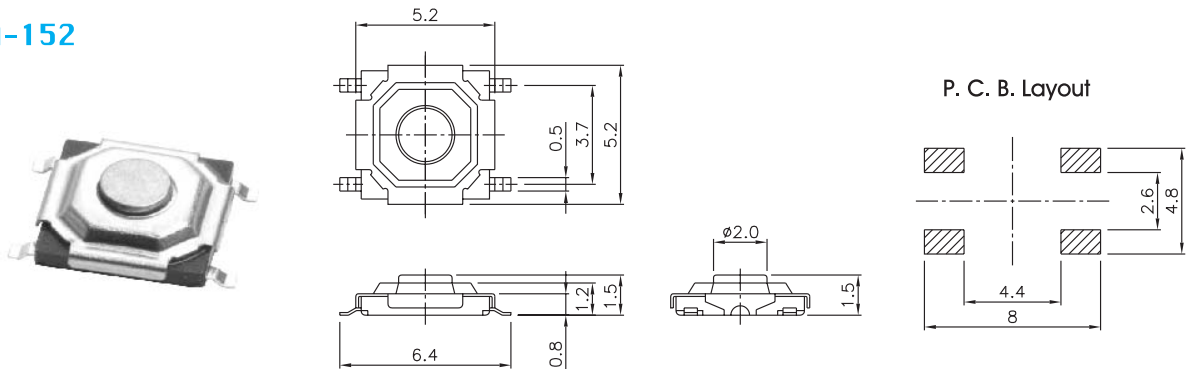

PTA-153

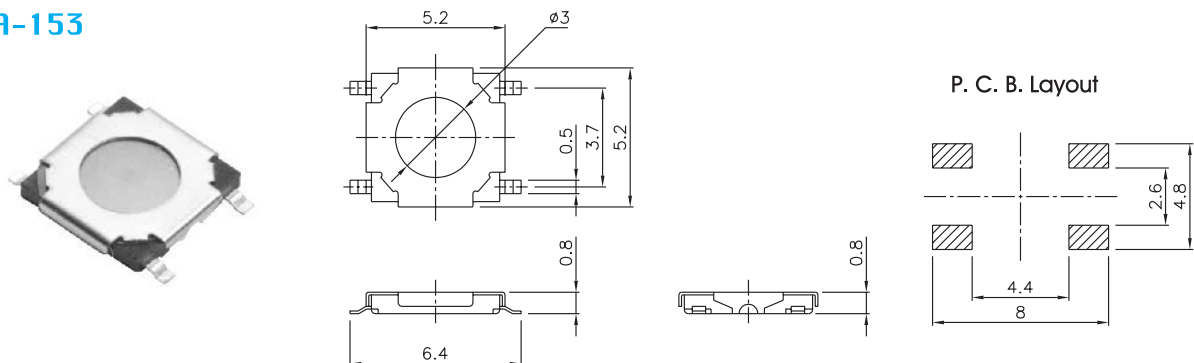

5.2 x 5.2 mm SMD Type

Dimensions (unit:mm)

PTA-154

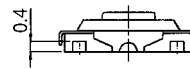
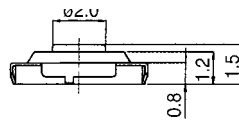
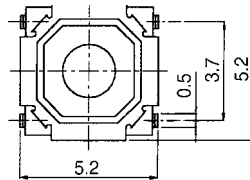
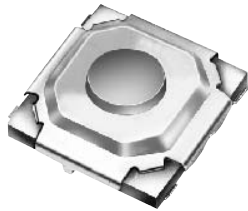

P. C. B. Layout

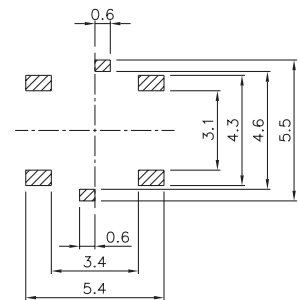

PTA-158

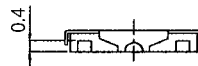
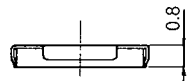
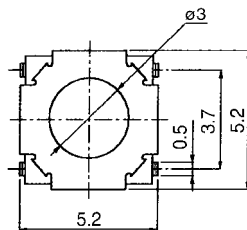

P. C. B. Layout

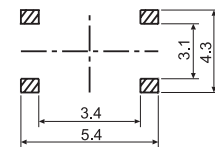

PTA-252

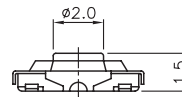
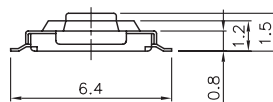
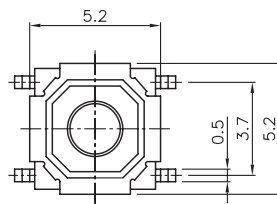

P. C. B. Layout

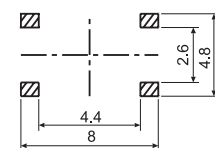

PTA-254

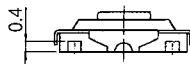
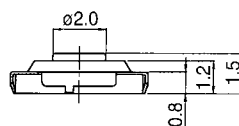
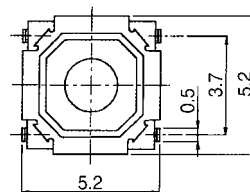
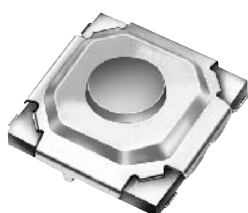

P. C. B. Layout

